

STEED

WITH CONTROLLED FERRO-RESONANT TECHNOLOGY

Installation and Operating Instructions



One Technology Place
Caledonia, NY 14423
(585) 538 – 4421
www.appliedenergysol.com

The Power of Excellence

FM1249
REV G

TABLE OF CONTENTS

SECTION 1	SAFETY INSTRUCTIONS	2
SECTION 2	RECEIPT AND INSPECTION OF THE CHARGER	3
SECTION 3	INTRODUCTION	3
SECTION 4	CONTROL FEATURES	3
SECTION 5	INSTALLATION	5
SECTION 6	CHARGER OPERATING PROCEDURE	8
SECTION 7	CHARGER CABINETS	11
SECTION 8	MAINTENANCE	12
SECTION 9	TROUBLESHOOTING GUIDE	15
SECTION 10	SCHEMATICS	17

SECTION 1 SAFETY INSTRUCTIONS

IMPORTANT SAFETY INSTRUCTIONS

1. SAVE THESE INSTRUCTIONS. THIS MANUAL CONTAINS IMPORTANT SAFETY AND OPERATING INSTRUCTIONS.
2. WORKING IN THE VICINITY OF A LEAD-ACID BATTERY IS DANGEROUS. BATTERIES GENERATE EXPLOSIVE GASSES DURING NORMAL BATTERY OPERATION. FOR THIS REASON IT IS OF THE UTMOST IMPORTANCE THAT EACH TIME BEFORE USING YOUR CHARGER, YOU READ AND FOLLOW THE INSTRUCTIONS PROVIDED EXACTLY.
3. TO REDUCE RISK OF BATTERY EXPLOSION, FOLLOW THESE INSTRUCTIONS AND THOSE ON THE BATTERY.
4. NEVER SMOKE OR ALLOW AN OPEN SPARK OR FLAME IN THE VICINITY OF THE BATTERY OR ENGINE.
5. USE CHARGER FOR CHARGING A LEAD-ACID BATTERY ONLY. IT IS NOT INTENDED TO SUPPLY POWER TO AN EXTRA LOW-VOLTAGE ELECTRICAL SYSTEM OR TO CHARGE DRY-CELL BATTERIES. CHARGING DRY-CELL BATTERIES MAY CAUSE THEM TO BURST AND CAUSE INJURY TO PERSONS AND DAMAGE TO PROPERTY.
6. NEVER CHARGE A FROZEN BATTERY.
7. DO NOT OPERATE IN A CLOSED-IN AREA OR RESTRICT VENTILATION IN ANY WAY.
8. DANGER: RISK OF ELECTRICAL SHOCK. DO NOT TOUCH UNINSULATED PORTION OF OUTPUT CONNECTOR OR UNINSULATED BATTERY TERMINAL.
9. CAUTION: DISCONNECT SUPPLY BEFORE CHANGING FUSE.

INSTRUCTIONS IMPORTANTES CONCERNANT LA SECURITE

1. CONSERVER CES INSTRUCTIONS. CE MANUEL CONTIENT DES INSTRUCTIONS IMPORTANTES CONCERNANT LA SECURITE ET LE FONCTIONNEMENT.
2. IL EST DANGEREUX DE TRAVAILLER A PROXIMITE D'UNE BATTERIE AU PLOMB. LES BATTERIES PRODUISENT DES GAS EXPLOSIFS EN SERVICE NORMAL. AUSSI EST-IL IMPORTANT DE TOUJOURS RELIRE LES INSTRUCTIONS AVANT D'UTILISER LE CHARGEUR ET DE LES SUIVRE A LA LETTRE.
3. POUR REDUIRE LE RISQUE D'EXPLOSION, LIRE CES INSTRUCTIONS ET CELLES QUI FIGURENT SUR LA BATTERIE.
4. NE JAMAIS FUMER PRES DE LA BATTERIE OU DU MOTEUR ET EVITER TOUTE ETINCELLE OU FLAMME NUE A PROXIMITE DE CES DERNIERS.
5. UTILISER LE CHARGEUR POUR CHARGER UNE BATTERIE AU PLOMB UNIQUEMENT. CE CHARGEUR N'EST PAS CONCU POUR ALIMENTER UN RESEAU ELECTRIQUE TRES BASSE TENSION NI POUR CHARGER DES PILES SECHES. LE FAIT D'UTILISER LE CHARGEUR POUR CHARGER DES PILES SECHES POURRAIT ENTRAINER L'ECLATEMENT DES PILES ET CAUSER DES BLESSURES OU DES COMMAGES.
6. NE JAMAIS CHARGER UNE BATTERIE GELEE.
7. NE PAS FAIRE FONCTIONNER LE CHARGEUR DANS UN ESPACE CLOS ET/OU NE PAS GENER LA VENTILATION.
8. DANGER: RISQUE DE CHOCS ELECTRIQUES. NE PAS TOUCHER LES PARTIES NON ISOLEES DU CONNECTEUR DE SORTIE OU LES BORNES NON ISOLEES DE L'ACCUMULATEUR.
9. ATTENTION: COUPER L'ALIMENTATION AVANT DE REMPLACER LES FUSIBLES.

SECTION 2 RECEIPT AND INSPECTION OF THE CHARGER

Upon receipt of the STEED Charger, the information on the shipping carton should be checked against your order.

All chargers can be handled with a lift truck by inserting the forks under the bottom of the charger. Remove the carton and inspect the charger for damage. If there is any damage, save the carton for inspection and notify the carrier immediately. Check the nameplate & labels against your order & specifications.

Any discrepancies should be reported immediately to the nearest Applied Energy Solutions authorized representative.

SECTION 3 INTRODUCTION

The STEED Charger is a full wave, silicon rectified ferro-resonant charger. Charging current and voltage are controlled by the control circuit. This charger is capable of charging AGM TYPE SEALED BATTERIES, SEALED GEL BATTERIES (GENERAL PROFILE), and FLOODED BATTERIES.

A solid state, pre-programmed microprocessor provides total control of charge termination, preventing both undercharging and overcharging. The charge is terminated automatically when the control determines that the battery is fully charged. Refer to section 6.3 for charge profiles

SECTION 4 CONTROL FEATURES

4.1 CONTROL FEATURES

- Automatic five second delayed start upon connection of a proper sized battery in good condition.
- Battery voltage sensing determines if there is a proper sized battery connected to the charger. This prevents charging if there is a bad battery, no battery connected, bad battery-to-charger connection or battery voltage and charger mismatch.
- Battery voltage and current are continuously monitored and controlled.
- Automatic dv/dt charge termination.
- Negative battery slope termination to prevent overcharge/thermal runaway.
- Automatic 24 hour "REFRESH" charge adds a top off charge to a fully charged battery. The charger will start a "refresh" charge 24 hours after a normal charge complete has been reached, assuming that the battery was not disconnected during that time.
- Back-up Timers prevent extended charging of a damaged battery. The first timer starts at the beginning of the charge cycle and runs for 9 hours. If the battery has not reached the gassing point the charger will shutdown. The second timer starts at the gassing point and runs for a period of time determined by the charge profile. If the charger has not completed its cycle by then it will shutdown.
- Automatic Shutdown Lock-out will not allow a charge to start after a manual or problem shutdown occurs. Automatic Shutdown Lock-out is cleared after the "Shutdown" battery is disconnected. This allows a charge to begin upon connection of a proper sized battery.
- Manual STOP switch - Will stop the charger from charging. The display will indicate "OFF" until the battery is disconnected. When pressed with no battery connected, displays the delay start setting.
- One to nine hour programmable delayed start thumbwheel switch. This rotary switch can be set from 0 to 9 hours to delay the start of charge.

- Equalize switch - This switch when depressed will turn on and off the three-hour additional equalizing charge. When the equalize function is turned on an “E” will be displayed in the left-most digit of the display and the CHARGE COMPLETE LED will flash on for 1/2 second and then off for 3 seconds until the charger goes into the equalize mode. The “E” will flash during the actual equalize charge cycle.
- Refresh mode - When the CHARGING and 80% LED’s light continuously and the CHARGE COMPLETE LED is flashing the charger is in the refresh mode. The refresh cycle is an additional charge at the finish rate current. This added charge period will start when the charger is left connected to a battery for 24 hrs after a normal charge cycle is complete. The charger will automatically charge at the finish rate current until dv/dt is detected or until the ceiling voltage limit is reached (Flooded battery only).
- Automatic shutdown occurs for any of the following seven failure conditions. The SHUTDOWN LED will flash when a shutdown occurs.
- Manual Jump Start – If the battery voltage is lower than 1.5 V/Cell, the charger can be manually started by pressing both STOP and EQUALIZE buttons. The charger will shut down within 5 minutes if the battery voltage does not reach 1.5 V/Cell.

- Fault Codes

Fault code “Lo U” - Low volts per cell - the battery voltage is less than 1.5 V/Cell. The charger will not be “locked off”. The charger will automatically start charging when the battery voltage is greater than 1.5 vpc.

Fault code “Hi U”-High volts per cell - greater than 2.65,2.75 or 2.80 vpc (set with 80% point)

Fault code “dISC” - Battery disconnected from charger during charge.

Fault code “dur” - Charge time duration exceeded - backup timer expired during “high rate” charge.

Fault code “Lo I”- Low charging current - charging current less than approx. 3 amps.

Fault code “Hi I” - The charger will shut down for high current if the output current is imbalanced or over the range for that model.

Fault code “Ph ” (three phase units only) - the incoming AC Voltage has improper phase rotation. Have a Qualified service person rotate the AC Input phasing to the charger.

- LED Indicators

“CHARGING” - charger is charging the battery.

“80%” - the battery voltage is greater than the preset gassing voltage, see section 5 for setting.

“CHARGE COMPLETE” - the charge cycle has been terminated normally.

If flashing slowly (1/2 second every 4 seconds), the charger is set to equalize at the end of the charge cycle.

If flashing on and off each second with the CHARGING and 80% LED’s lit continuously then the charger is in the refresh mode.

“SHUTDOWN” - the unit has shut down for a fault.

- AMMETER/TIMER Readout will display the following information:

Charging current

Fault codes

Delay start time

Equalize mode

Number of charge cycles remaining until the next Auto Equalize mode.

Amp-Hours returned for this charge cycle.

Charging time - the length of time the charger was charging.

Volts per Cell - the average battery cell voltage.

- **DISPLAY MODE BUTTON:**

Press once to display the AMP-HRS returned this charge cycle.

Press twice to display the length of CHARGE this cycle.

Press three times to display the AVERAGE VOLTS per CELL of the battery.

The display will show the above function for approximately 10 seconds and then return to display charge current or the sequencing dash.

- **LED TEST BUTTON:** Pressing the LED TEST button will illuminate all display segments and all LED's.

SECTION 5 INSTALLATION

5.1 PHYSICAL LOCATION:

Charging areas should be clean and dry. The temperature of the charging room should be between 32 deg F (0 deg C) and 77deg F (25 deg C), with occasional and brief periods of ambient temperature as high as 104 deg F (40 deg C). Combustible materials, open flames and smoking should not be permitted near or in the charging room.

WARNING

A BATTERY ON CHARGE WILL EMIT EXPLOSIVE GAS.
VENTILATE THE CHARGING ROOM TO PREVENT GAS ACCUMULATION.

5.2 MOUNTING:

The charger cabinets must be mounted on a surface constructed from non-combustible material, such as stone, brick, concrete or metal. Mounting holes are provided in the frame for securing the charger.

5.3 INPUT POWER CONNECTION:

THE 3 PHASE STEED CHARGERS ARE PHASE ROTATION SENSITIVE; PLEASE ENSURE THAT CLOCKWISE PHASE ROTATION IS OBSERVED. SEE SECTION 4.1 FOR IMPROPER PHASE ROTATION FAULT CODE, OR SECTION 9 (TROUBLE SHOOTING GUIDE).

The chargers are shipped from the factory connected for the input voltage specified on your purchase order. A "STOP/CAUTION" label, located inside the door, indicates the factory set input voltage.

WARNING

VERIFY THE AC ELECTRICAL SERVICE IS DISCONNECTED AT THE SOURCE
BEFORE ATTEMPTING TO CONNECT AC POWER TO THE CHARGER.

The AC input terminals are identified by a red-on-white AC INPUT sticker located on the base near the fuse block. The AC input cable is to be connected to the proper AC INPUT terminals within the charger cabinet.

The fuse block's input terminals are rated for 14 AWG to 2 AWG wire. The recommended torque is listed on the fuse block itself.

A bare wire, green or green with yellow striped grounding wire is to be connected from the Grounding Terminal within the charger cabinet to the service system ground. The Grounding Terminal is identified by a green-on-white Ground Terminal Label on the charger base. If a system ground is not available, the charger frame must be connected to a driven ground rod in accordance with National and Local electrical codes. Proper application and tight terminal connections are important in avoiding future problems. The ground terminal is rated for 14 awg to 6 awg wire. The recommended torque setting is shown in Table 5.1

Table 5.1

Wire Gauge	Recommended Torque Setting
PANDUIT LAMA6-14Q	
6 – 10 AWG	40 in lbs
12 – 14 AWG	15 in lbs
T&B ADR6	
6 AWG	35 in lbs
8 – 14 AWG	20 in lbs

The charger is normally furnished with an output charge plug or receptacle. Verify that the connectors on both the battery and the charger are correct. Verify that when connected, the positive polarity (red) of the charger is connected to the positive terminal of the battery.

If the charger is to be used at a different AC voltage than is presently set for, the charger may be adjusted to operate for the different AC service. Refer to SECTION 8.2. CHANGING THE AC INPUT LINE VOLTAGE.

5.4 Setting Charger DIP Switches

The STEED chargers are designed to charge both flooded and sealed batteries. The charger is equipped with switches that determine the charge profile settings. ***The utmost care must be used when setting the switches as incorrect settings can undercharge, overcharge or even damage the battery and / or charger.***

Table 1. Amp-Hour Rating

S6-1	S6-2	S6-3	S6-4	AMPERE-HOUR RATING 1 PH (AH)	AMPERE-HOUR RATING 3 PH (AH)
OFF	OFF	OFF	OFF	180	380
ON	OFF	OFF	OFF	260	475
OFF	ON	OFF	OFF	380	600
ON	ON	OFF	OFF	475	750
OFF	OFF	ON	OFF	540	865
ON	OFF	ON	OFF	600	965
OFF	ON	ON	OFF	680	1050
ON	ON	ON	OFF	750	1200
OFF	OFF	OFF	ON	865	1450
ON	OFF	OFF	ON	965	Reserved
OFF	ON	OFF	ON	Reserved	Reserved
ON	ON	OFF	ON	Reserved	Reserved
OFF	OFF	ON	ON	Reserved	Reserved
ON	OFF	ON	ON	Reserved	Reserved
OFF	ON	ON	ON	Reserved	Reserved
ON	ON	ON	ON	Reserved	Reserved

Table 2. Profiles

S2-1	S2-2	BATTERY	PROFILE
OFF	OFF	GEN GEL Sealed LA	I/E/I 16.0A/2.40V/1.5A
ON	OFF	AGM Sealed LA	I/E/I 15.5A/2.37V/3.0A
OFF	ON	Flooded (Regular) LA	P/E/I 18.0A/2.37V/5.0A
ON	ON	Flooded (Tubular) LA	P/E/I 18.0A/2.45V/5.0A

S2-3 & 4 are reserved

Table 3. Auto Equalize

S6-5	AUTO EQUALIZE
OFF	Disabled
ON	Every 7th Charge Cycle

Table 4. Cool-down Display

S6-6	COOL-DOWN TIME DISPLAY
OFF	Display Time Since Last Complete Charge Cycle
ON	Disabled

Table 5. Auto Refresh

S6-7	AUTO REFRESH
OFF	Disabled
ON	Enabled

Table 6. Auto Refresh Information

S6-8	REFRESH INFORMATION
OFF	Excluded
ON	Included

Note: Shaded areas are default setting.

SECTION 6 CHARGER OPERATING PROCEDURE

6.1 PRELIMINARY SET-UP:

With all power removed from the charger set the DIP switches per the previous tables before attempting to charge a battery.

Once power has been applied to the charger, a "dash" will sequence across the display on the front panel. This indicates the charger is in the "IDLE MODE" of operation, awaiting a battery connection.

6.2 IMMEDIATE/DELAY START:

The control may be programmed to delay the start of the charge from one to nine hours as well as an immediate start of the charge upon battery to charger connection. Note that all units are shipped from the factory set for immediate start (0 hour delay). If a power failure occurs, no damage will occur to the battery or the charger. If a battery is still connected when power returns, the charger will override any delayed start setting and initialize an immediate start of the charge. Once the charge has been terminated, the delay start will function normally thereafter.

The following steps are to set the start delay:

- Remove AC power from the charger.
- Open the charger cabinet door.
- Locate the DELAY START thumbwheel switch behind the front panel at the bottom of the main control board. Adjust the DELAY START thumbwheel switch until the NUMBER INDICATOR on the switch yields the number of delay hours desired.
- Close and secure the cabinet door.
- Apply AC power to the charger.
- Without a battery connected the setting may be checked by pressing and holding the stop button. When a good, proper sized battery is connected to the charger, the display will indicate the amount of time before the charge is initiated and the timer will countdown.

6.3 CHARGING THE BATTERY:

Compare the number of cells and amp-hour capacity of the battery to be charged with the charger rating found on the charger nameplate. The number of cells in the battery to be charged MUST match the nameplate data. The amp-hour ratings should also match for timely charging of the battery. Once the battery to be charged has been determined to match the charger, then connect the battery to the charger. The control will measure the average volts/cell of the connected battery.

If the control has verified the connection of a good battery (between 1.5 and 2.7 volts/cell), the display will show a countdown to charge initialization and the LED's will be flashing. When the countdown reaches zero, the charger control will start the charging operation.

If the average volts/cell reading is less than 1.5 volts, the display shows "Lo U", the charge will not begin and the Red SHUTDOWN LED will be flashing. If the battery voltage "floats" above 1.5 V/Cell the charger will automatically begin a normal charge cycle.

To override the “Lo U” condition press and hold the Stop and Equalize buttons for ten seconds. The charger will begin charging. If the battery voltage does not rise above the 1.5 V/Cell limit within 5 minutes the charger will be locked off and the override function will not work.

When charging an overly discharged or sulfated battery the battery voltage may rise very quickly for the first few minutes and then return to the “normal” voltage. If the peak voltage reaches the gassing point and then falls more than 50 MV per cell below the gassing point the charger will shut off. The SHUTDOWN LED will be flashing and the readout will display a sequenced bar.

If the average volts/cell is greater than 2.7 volts, display shows “HI U”; and the Red SHUTDOWN LED will turn on. Again, the charge will not begin. Once the charge begins, the display will count down from 9 to 0 then show the output charging current in amperes. The Green CHARGING LED will be on. The chargers offer a three-stage charge cycle. The Green CHARGING LED will illuminate throughout the charge cycle. The cycle starts with high rate, constant current. The 80% CHARGED LED will illuminate when the gassing point is reached.

SET FOR GEN GEL BATTERY

The charger’s microprocessor adjusts the output so that the charger is in constant current mode (16A/100Ahr) until the battery reaches the gassing voltage (2.40V/Cell). After the gassing voltage is reached the charger maintains this battery voltage and allows the charging current to slowly decrease until it reaches the finish current (1.5A/100Ahr). When the current reaches the finish current value, the charger will maintain the constant current mode (1.5A/100Ahr) for three hours.

SET FOR AGM SEALED GEL BATTERY

The charger’s microprocessor adjusts the output so that the charger is in constant current mode (15A/100Ahr) until the battery reaches the gassing voltage (2.37V/Cell). After the gassing voltage is reached the charger maintains the battery voltage and allows the charging current to slowly decrease until it reaches the finish current (3A/100Ahr). When the current reaches the finish current value, the charger again returns to the constant current mode until one of the following conditions is reached:

- DV/DT, OR
- 3.5 hours from the gassing point

SET FOR FLOODED BATTERY (REGULAR OR TUBULAR)

The charger’s microprocessor adjusts the output so that the charger is in constant power mode (18A/100Ahr @2.235V/Cell) until the battery reaches the gassing voltage (2.37 or 2.45 V/Cell). When the gassing voltage is reached the charger maintains the battery voltage and allows the charging current to slowly decrease until it reaches the finish current value (5A/100Ahr). When the current drops to the finish current the charger will stay in the constant current mode until one of the following conditions is reached:

- DV/DT, OR
- 6 hours from the gassing point.

6.4 CHARGE TERMINATION

6.4.1 MANUAL TERMINATION, while charging, is accomplished by pressing the STOP push-button switch located on the front panel.

WARNING

To remove a charging battery from the charger, it is important to press the STOP push-button switch first before disconnecting the battery from the charger. Failure to do this may damage the charger.

When the charge has been terminated due to MANUAL TERMINATION, the Red SHUTDOWN LED will be on solid until the battery is removed. The display will show "OFF".

6.4.2 PROBLEM SHUTDOWN

Each of the PROBLEM SHUTDOWN terminations is indicated by a flashing Red SHUTDOWN LED and a FAULT code. After the battery is removed, the Red SHUTDOWN LED will remain flashing. The display indicator will remain ON until the battery is disconnected from the charger. Refer to SECTION 4.1 for a more complete explanation of the diagnostics.

6.5 REFRESH CHARGE (Flooded profile only):

When a battery remains connected to the charger for 24 hours after the charge has been completed, the control will restart another charge cycle. The charge rate of the battery will be monitored with dv/dt termination occurring typically within 45 minutes. When the charger is in this REFRESH mode the charge amps will be displayed and the CHARGING LED and 80% CHARGED LED will be ON and the CHARGE COMPLETE LED will be blinking.

6.6 THREE HOUR EQUALIZE:

Manual Equalize: The EQUALIZE button when pushed will provide a timed three hour charge extension after dv/dt termination has been reached. To cancel this function, press the push-button again. The first digit of the front panel display will display "E" and the CHARGE COMPLETE LED will blink once every 4 seconds to indicate that the Equalize Charge is selected. When the charger is actually in the Equalize mode the "E" will be flashing.

Auto Equalize: The Auto Equalize is also activated after seven charge cycles. The first digit of the front panel display will display "E" to indicate that the Equalize Charge is selected. The number of charge cycles remaining until the next equalize charge can be checked by pressing the Manual Equalize pushbutton while the battery is not connected. The first digit of the front panel display will display "E" and the CHARGE COMPLETE LED will blink once every 4 seconds to indicate that the Equalize Charge is selected. When the charger is actually in the Equalize mode the "E" will be flashing.

6.7 BATTERY LOW VOLTS OVERRIDE

If the battery voltage measures less than 1.5 volts per cell, the charger may be started manually, by pressing and holding two push buttons (Stop and Equalize) for more than 10 seconds. If the battery does not increase above 1.5 V/Cell in 5 minutes the charger will shut off and indicate Low Volts Alarm again, otherwise the normal charge cycle will continue. This "grace period" is intended to give the battery time to recover from it's over discharged condition.

SECTION 7 CHARGER CABINETS

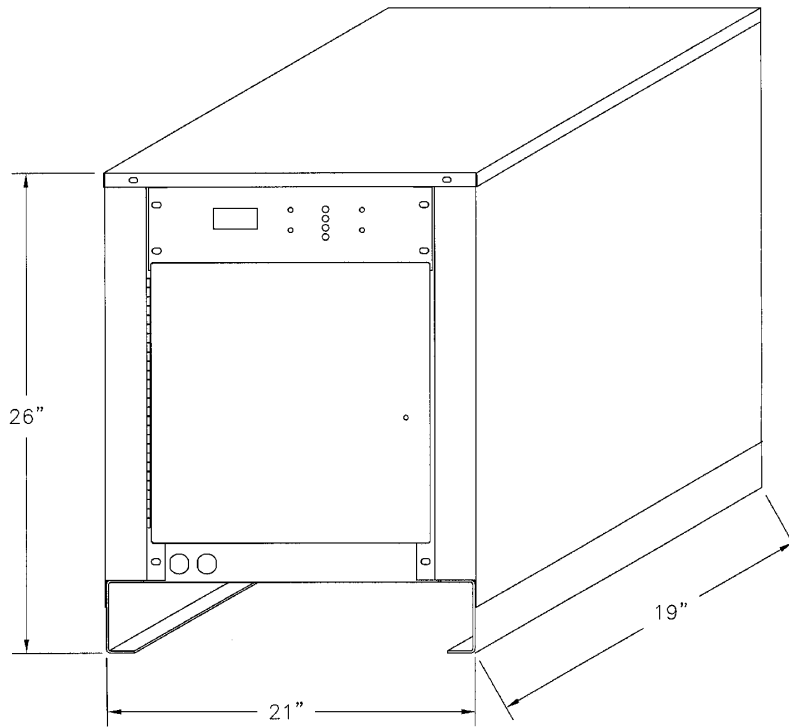

SINGLE PHASE

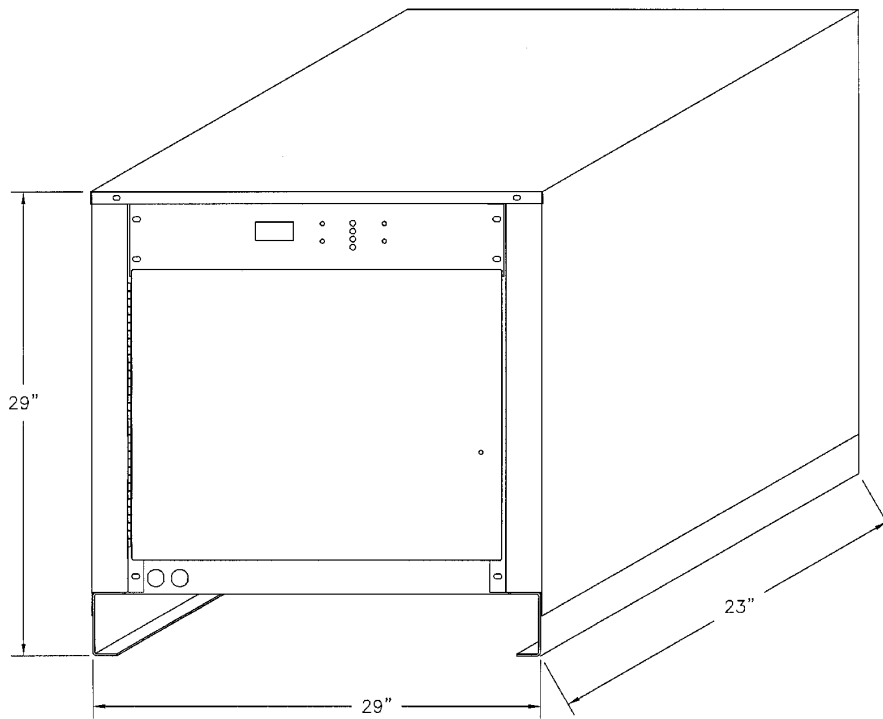

THREE PHASE

SECTION 8 MAINTENANCE

IMPORTANT

BEFORE PERFORMING ANY MAINTENANCE ON THE CHARGER:

- If a battery is being charged, terminate the charge by pressing the STOP button.
- Disconnect the battery from the charger.
- Remove AC power from the charger.

WARNING

HIGH VOLTAGES EXIST WITHIN THE CHARGER WHICH CAN CAUSE SEVERE INJURY OR DEATH. SERVICE SHOULD ONLY BE PERFORMED BY QUALIFIED SERVICE PERSONNEL. IMPROPER SERVICING MAY DAMAGE THE CHARGER.

8.1 MONTHLY PREVENTIVE MAINTENANCE

- If a battery is being charged, terminate the charge by pressing the STOP button.
- Disconnect the battery from the charger.
- Remove AC power from the charger.
- Using compressed air, remove any dust from the inner cabinet walls and internal components of the charger.
- Wipe the exterior of the cabinet and clear any obstructions from the ventilation louvers.
- Make sure that all bolted or screwed electrical connections are tight.
- Make sure that the insulation on all cables and wires is in good condition. Replace if necessary.

8.2 CHARGER ADJUSTMENTS

- CHANGING THE AC INPUT LINE VOLTAGE:

The STEED chargers are designed to operate at different voltage levels. Single phase chargers can be ordered for 120/240 volts, 208/240/480 volts or 240/480/575 volts 60 Hz electric services depending on the charger. Three phase chargers can be ordered for 208/240/480 volts or 240/480/575 volts 60 Hz electric services.

If the charger is to be operated on a different rated input voltage than the ordered value, follow the voltage changeover instructions described below (Refer to FIGURES 8.2.1A through 8.2.1E.).

- VOLTAGE CHANGEOVER INSTRUCTIONS:

1. Manually terminate the charging battery by pressing the STOP button and disconnect battery from charger.

2. Remove AC power from the charger.

3. Locate the Terminal Block with Jumpers (one Terminal Block per phase. and the label describing the various voltage/jumper configurations) (Refer to FIGURE 8.2.1A, B, C, D OR E). The Terminal Block with Jumpers are located on the Ferro-resonant Transformer.

4. Change the jumpers in accordance with the Jumper label, located within the charger cabinet, for the voltage input configuration desired.

5. Locate the AC fuses and fuse label. Change the fuses to the appropriate value as indicated by the circled values on the fuse label.

6. Locate the Control transformer. Change the primary input connection in accordance with the voltage printed on the transformer. (Refer to FIGURE 8.2.2A through D.)

7. Change the voltage level on the STOP label to the new voltage level.

8. CHECKLIST:

a) Verify the Terminal Block(s) with Jumpers is/are configured correctly. Make sure that all the Terminal Blocks with Jumpers have been changed properly.

b) Verify the installation of properly rated fuses.

c) Verify that the Control Transformer primary taps have been changed correctly.

d) Verify the STOP label, located inside the door, has been corrected to the new input voltage level that the charger is set for.

9. Close and secure the cabinet.

10. Connect the AC power to the charger.

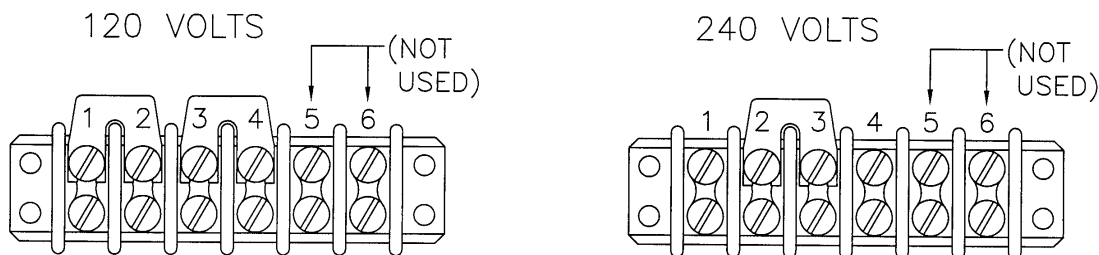

FIGURE 8.2.1A A.C. VOLTAGE SELECTOR BLOCKS (SINGLE PHASE UNITS ONLY)

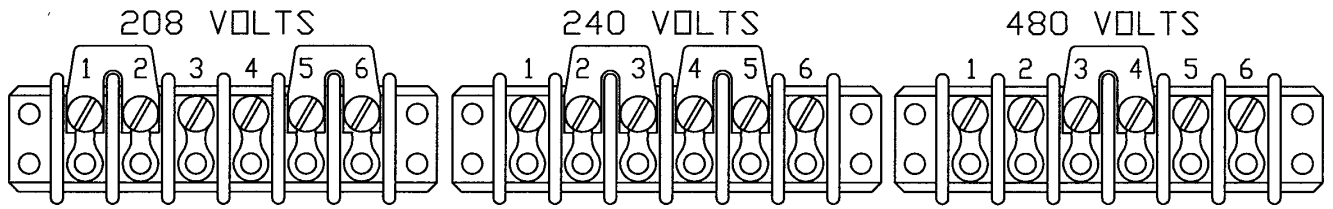

FIGURE 8.2.1B A.C. VOLTAGE SELECTOR BLOCKS (SINGLE PHASE UNITS ONLY)

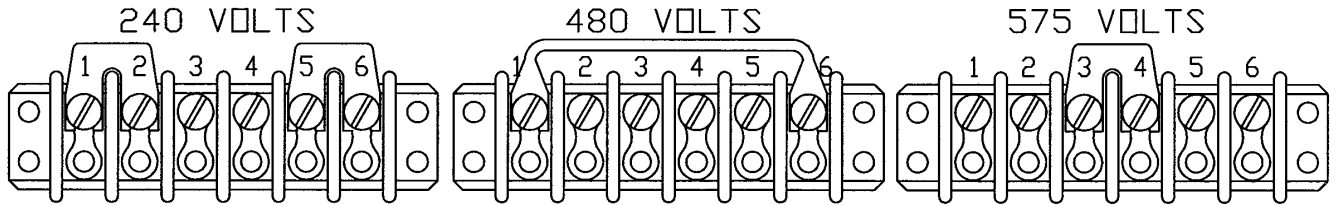

FIGURE 8.2.1C A.C. VOLTAGE SELECTOR BLOCKS (SINGLE PHASE UNITS ONLY)

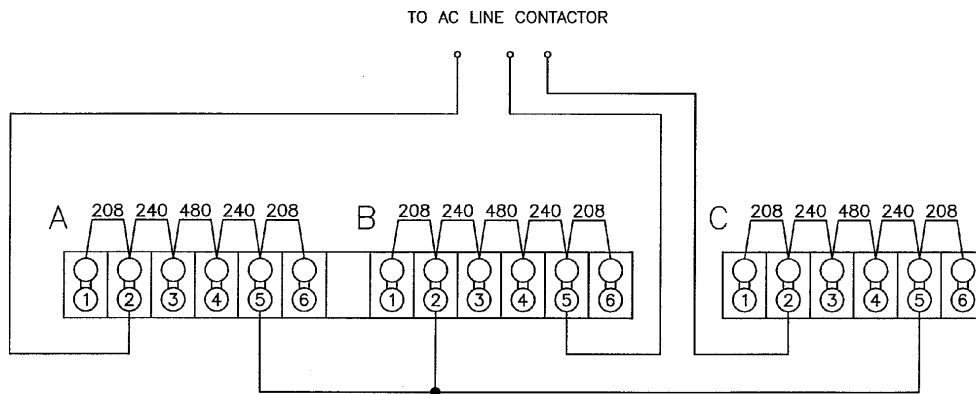

FIGURE 8.2.1D A.C. VOLTAGE SELECTOR BLOCKS (THREE PHASE UNITS ONLY)

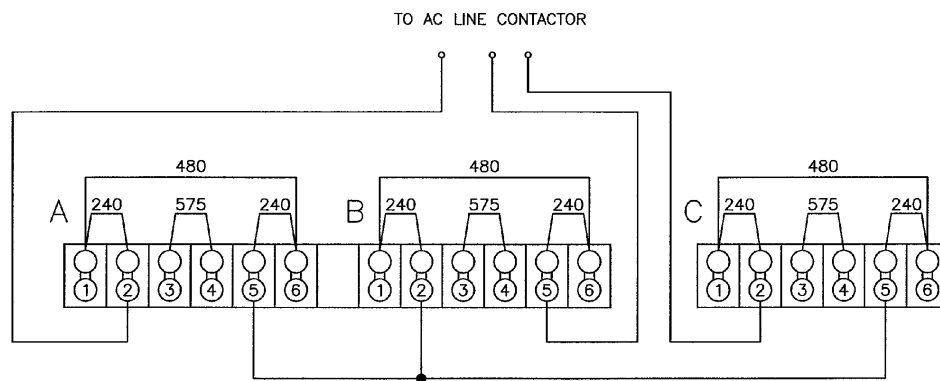

FIGURE 8.2.1E A.C. VOLTAGE SELECTOR BLOCKS (THREE PHASE UNITS ONLY)

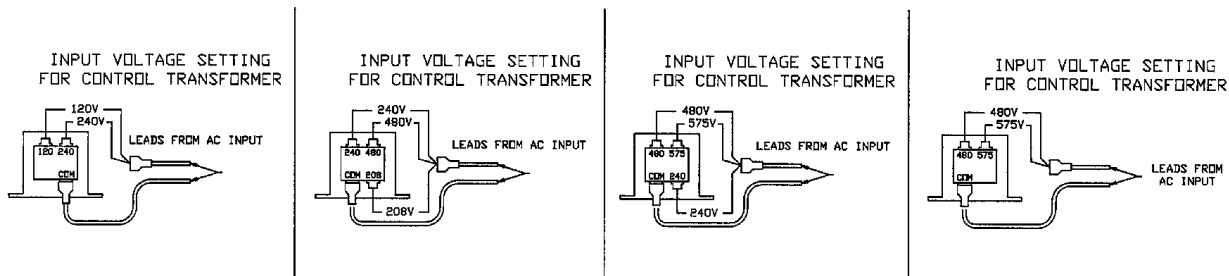

FIGURE 8.2.2A, B, C, D
A.C. VOLTAGE SELECTION ON PRIMARY SIDE OF CONTROL TRANSFORMER

- CHARGING CURRENT START & FINISH RATE ADJUSTMENT:

WARNING

HIGH VOLTAGES EXIST WITHIN THE CHARGER WHICH CAN CAUSE SEVERE INJURY OR DEATH. SERVICE SHOULD ONLY BE PERFORMED BY QUALIFIED SERVICE PERSONNEL. IMPROPER SERVICING MAY DAMAGE THE CHARGER.

The charge profile is determined by the control board settings. The capacitor taps are set for optimum performance at the factory. **Do not attempt to adjust the capacitor taps without written factory instructions and approval.**

SECTION 9 TROUBLESHOOTING GUIDE

SYMPTOM 1 POWER IS APPLIED BUT THE DISPLAY IS NOT ON

- Make sure the input line from the AC power outlet is connected at the AC fuse block properly. Verify the AC voltage at the fuse block.
- Locate the control transformer. Verify the voltage at the primary of the transformer. If there is no voltage, check the wiring between the control transformer and the contactor.
- Verify the secondary voltage of the control transformer across terminals 5 and 7. The voltage should be approximately 18-20 Volts RMS. If there is no voltage, the transformer is defective and should be replaced. If the secondary voltage is extremely high or low, verify that the AC voltage is connected to the proper primary inputs of the control transformer. (Refer to SECTION 8.2)
- Locate the Main Control Board and the Cell Select Board. Verify the proper connection of the boards and cables.

SYMPTOM 2 DISPLAY IS ON BUT CHARGER WILL NOT START

- If the “sequenced dash” is displayed, check the battery connections and the output fuse for open fuse.
- If “Hi U” is displayed, verify that the number of cells of the battery to be charged matches the number of cells on the nameplate.
- If “Lo U” is displayed, verify that the number of cells of the battery to be charged matches the number of cells on the nameplate. If the number of cells matches, the battery might have been over-discharged. Refer to SECTION 6.3 for Low Volts Override operation.

SYMPTOM 3 DISPLAY COUNTS DOWN BUT SHUTDOWN IMMEDIATELY

- If “Ph” is displayed (THREE PHASE), check the phase sequence. If the problem persists, check all wiring connections referring to SECTION 10 SCHEMATICS.
- If “Hi I” is displayed (SINGLE PHASE), check all wiring connections referring to SECTION 10 SCHEMATICS.

Following checklist should be performed to resolve this problem:

SINGLE PHASE:

- Is “COMMON” of the control transformer connected to L1 of the contactor?
- Is the other terminal of the control transformer connected to L3 of the contactor?
- Is terminal T1 of the contactor connected to terminal 1 (120/240V) or 2 (other input voltages) of the main transformer?
- Is terminal T3 of the contactor connected to terminal 4 (120/240V) or 5 (other input voltages) of the main transformer?
- Are cable from capacitor winding 7 (or 8 or 9) and cable from terminal M2 of the control assembly connected to the same side of the resonant capacitor?
- Is cable from capacitor winding 12 (or 11 or 10) connected to the power resistor mounted near the capacitor?
- Is the cable from the other side of the power resistor connected to terminal M1 of the control assembly?

THREE PHASE

- Is cable harness connected properly between the main control board and the inductor board?
- Is “COMMON” of the control transformer connected to L1 of the contactor?
- Is the other terminal of the control transformer connected to L3 of the contactor?
- Is terminal T1 of the contactor connected to terminal A2 of the main transformer T1 (transformer with 12 position terminal block)?
- Is terminal T2 of the contactor connected to terminal B5 of the main transformer T1 (transformer with 12 position terminal block)?
- Is terminal T3 of the contactor connected to terminal C2 of the second transformer T2 (transformer with 6 position terminal block)?
- Are terminals A5, B2 and C5 connected together?
- Are cable from capacitor winding 7 of the main transformer T1 and cable from terminal M3 of the inductor board connected to the same side of the resonant capacitor?

- Is cable from capacitor winding 8 of the main transformer T1 connected to the power resistor mounted near the capacitor?
- Are the cable from the other side of the power resistor and the cable from terminal M4 of the control assembly connected to the same side of the capacitor?
- Are cable from capacitor winding 7 of the second transformer T2 and cable from terminal M1 of the inductor board connected to the same side of the resonant capacitor?
- Is cable from capacitor winding 8 of the second transformer T2 connected to the power resistor mounted near the capacitor?
- Are the cable from the other side of the power resistor and the cable from terminal M2 of the control assembly connected to the same side of the capacitor?

SYMPTOM 4 CHARGE TERMINATES EARLY

- Fault code "**Lo U**" - Low volts per cell - the average battery voltage is less than 1.5 V/Cell. Check for bad cells.
- Fault code "**Hi U**"- High volts per cell - the average battery voltage is greater than the high voltage limit. The battery may be fully charged before connecting to the charger.
- Fault code "**disc**" - Battery is disconnected from charger during charge.
- Fault code "**dur**" - Charge time exceeded – the battery voltage did not reach the gassing point within 9 hours. Check for bad cells or deep discharge condition.
- Fault code "**Lo I**"- Low charging current – no charging current detected or charging current is too low. Check the DC fuse for open fuse.
- Display "**OFF**" – Charge cycle is terminated by pressing the STOP button.
- Display "**Sequenced dash**" and Fault LED ON: Battery is sulfated. Disconnect and re-connect the battery to start again.

SECTION 10 SCHEMATICS

See following pages

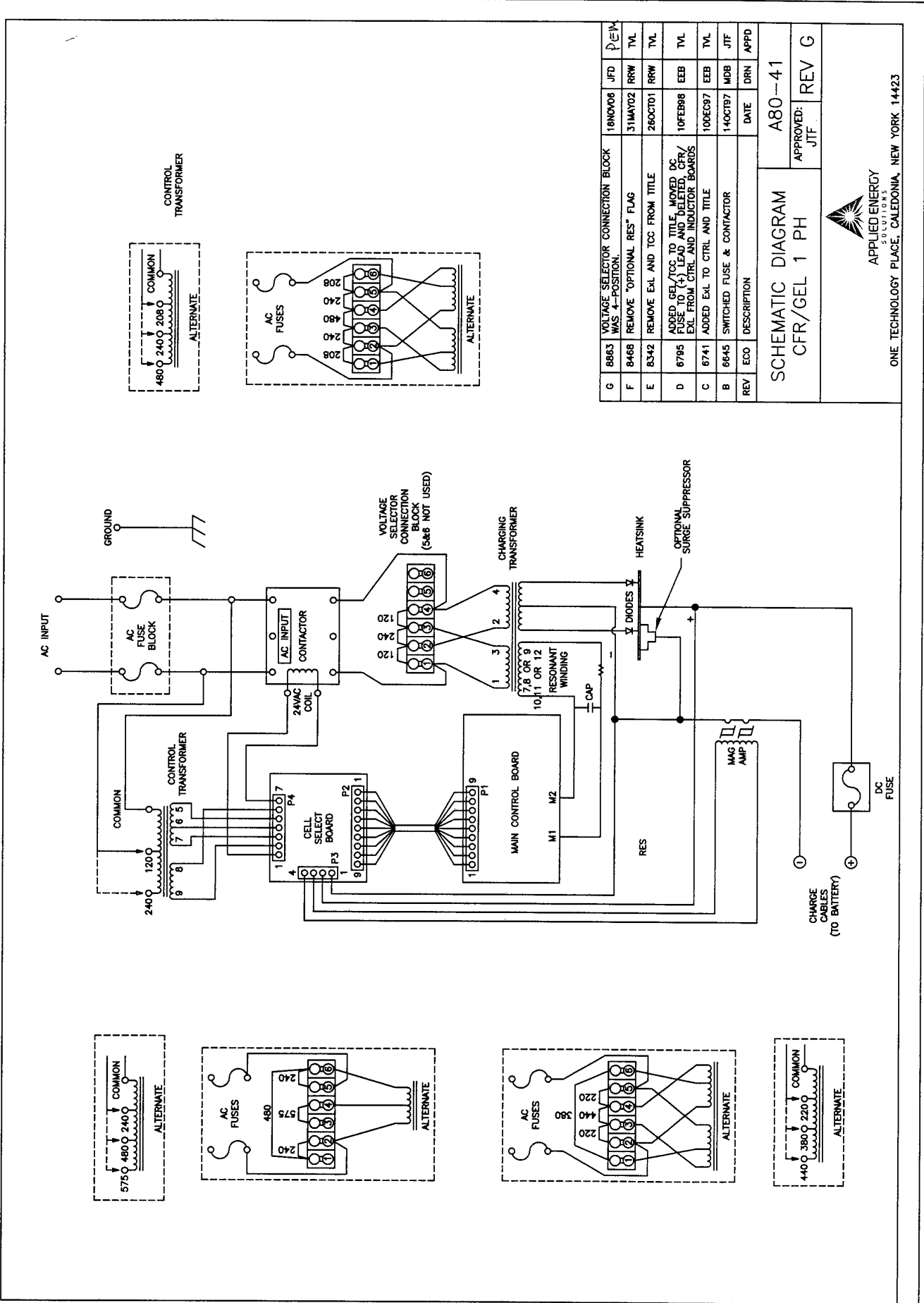

REV	ECO	DESCRIPTION	DATE	DRN	APPD
B	6645	SWITCHED FUSE & CONTACTOR	14OCT97	MDB	JTF
C	6741	ADDED EXL TO CTRL. AND TITLE	10DEC97	EEB	JTF
D	6795	ADDED GEL/TCC TO TITLE, MOVED DC FUSE TO (+) LEAD AND DELETED CRY/EXL FROM CTRL AND INDUCTION BOARDS	10FEB98	EEB	TVL
E	8342	REMOVE EXL AND TCC FROM TITLE	26OCT01	RRW	TVL
F	8468	REMOVE "OPTIONAL RES" FLAG	31MAY02	RRW	TVL
G	8883	VOLTAGE SELECTOR CONNECTION BLOCK WAS 4-POSITION.	16NOV06	JFD	PEM

SCHEMATIC DIAGRAM
CFR/GEL 1 PH

A80-41
APPROVED: JTF
REV G

APPLIED ENERGY SOLUTIONS
ONE TECHNOLOGY PLACE, CALEDONIA, NEW YORK 14423

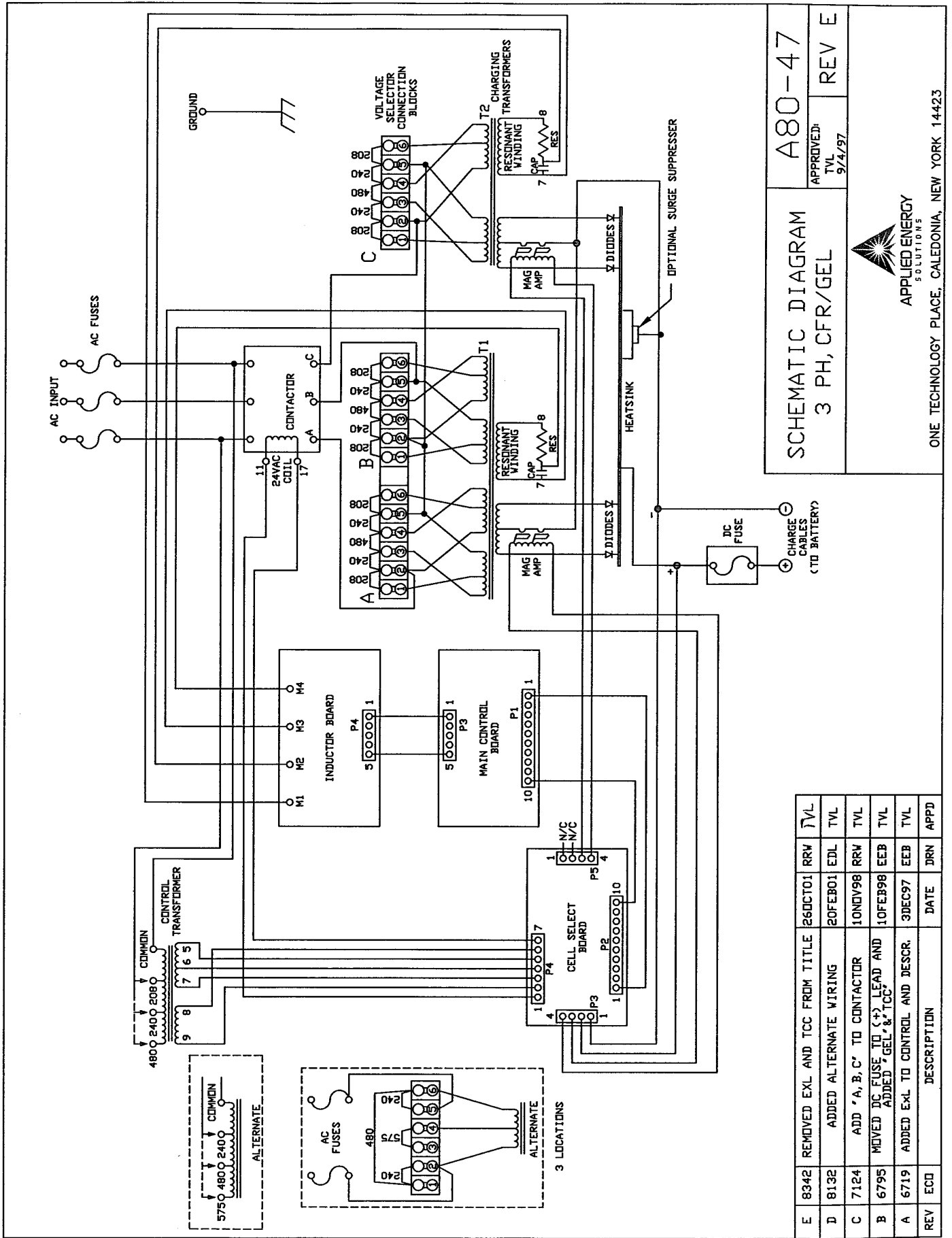

A80-47

SCHEMATIC DIAGRAM
3 PH, CFR/GEL

APPROVED:
TVL
9/4/97

REV E

APPLIED ENERGY SOLUTIONS

ONE TECHNOLOGY PLACE, CALEDONIA, NEW YORK 14423

REV	ECD	DESCRIPTION	DATE	DRN	APPD
E	8342	REMOVED EXL AND TCC FROM TITLE	26OCT01	RRV	TVL
D	8132	ADDED ALTERNATE WIRING	20FEB01	EDL	TVL
C	7124	ADD 'A, B, C' TO CONTACTOR	10NOV98	RRV	TVL
B	6795	MOVED DC FUSE TO (+) LEAD AND ADDED 'GEL' & 'TCC'	10FEB98	EEB	TVL
A	6719	ADDED EXL TO CONTROL AND DESC.	3DEC97	EEB	TVL

CHARGER WARRANTY

APPLIED ENERGY SOLUTIONS warrants that each new and unused battery charger manufactured and supplied with good workmanship is free from any known mechanical defect, provided that (A) the product is installed and operated in accordance with the accepted industrial standards and in accordance with the printed instructions furnished by APPLIED ENERGY SOLUTIONS, (B) the product is used under normal conditions for which designed, (C) the product is not used in a corrosive, abnormally dusty or high humidity moisture condensing environment, and (D) the product is not subjected to misuse or negligence, and the product receives proper care, protection and maintenance under supervision of competent personnel.

Warranty Terms and Conditions

APPLIED ENERGY SOLUTIONS Steed Industrial Battery Chargers are warranted for 10 Years⁽¹⁾, which begins on the date of shipment from APPLIED ENERGY SOLUTIONS.

NOTES: ⁽¹⁾Warranty covers parts and labor

AC fuses and DC fuses are not warranted unless they are found to be defective prior to use.

NON-TRANSFERABLE WARRANTY. This warranty is extended by APPLIED ENERGY SOLUTIONS only to the original user (purchaser) of new equipment from APPLIED ENERGY SOLUTIONS or one of its authorized agents. The product purchased under this agreement shall be used exclusively by the buyer. There shall be no third party beneficiary of this warranty.

REPAIR LIMITATIONS. APPLIED ENERGY SOLUTIONS has the right to site inspection and judgment of the claimed defects in any product covered by this warranty. APPLIED ENERGY SOLUTIONS' liability is limited to the repair of any defects found to exist by APPLIED ENERGY SOLUTIONS or, at APPLIED ENERGY SOLUTIONS' option, the replacement of the defective product.

APPLIED ENERGY SOLUTIONS and its authorized agents shall not be liable for direct or indirect damages in excess of such repair or replacement. In no event shall the purchaser be entitled to recover for contingent expenses from, but not limited to, telephone calls, telegrams, travel expenses, lodging, duties and taxes, labor, rental or replacement equipment, loss of business or profit or other commercial losses.

CONTINUED USE OF DEFECTIVE PRODUCTS. The continued use of an APPLIED ENERGY SOLUTIONS Industrial Battery Charger that is known to be defective VOIDS ALL WARRANTIES.

REPAIR OF MODIFIED EQUIPMENT. Except as authorized in writing the warranty specified does not cover any equipment that has been repaired by any party other than APPLIED ENERGY SOLUTIONS or its authorized agents. Except as authorized in writing the warranty specified does not cover any equipment that has been modified, mechanically or electrically, by any party other than APPLIED ENERGY SOLUTIONS.

WARRANTY EXPENSE LIMITATIONS. APPLIED ENERGY SOLUTIONS will limit the warranty expense of all chargers to be paid at a maximum of the original purchase price of the charger.

The provisions of this warranty shall not apply to product in use outside of the continental USA.

Except as stated above, all other warranties and conditions, either expressed or implied, including implied warranties of merchantability and fitness for a particular purpose, are excluded and buyer assumes all risk and liability resulting from the use of the goods. APPLIED ENERGY SOLUTIONS neither assumes or authorizes any persons to assume for APPLIED ENERGY SOLUTIONS any other liability in connection with the sale or use of the goods sold and there are no oral agreements or warranties collateral to or affecting this written warranty.

When installing, servicing or operating these products, safe practices should be used by skilled and qualified technical persons.