

# Maverick

High Frequency Opportunity Charger  
with TCC 2.0 Controller

Installation and Operating Instructions



One Technology Place  
Caledonia, NY 14423 (585)  
538 – 4421  
[www.appliedenergysol.com](http://www.appliedenergysol.com)

*The Power of Excellence*

FM1319  
REV B



**TABLE OF CONTENTS**

<b>SECTION 1</b>	<b>SAFETY INSTRUCTIONS</b> .....	<b>3</b>
<b>SECTION 2</b>	<b>RECEIPT AND INSPECTION OF THE CHARGER</b> .....	<b>4</b>
<b>SECTION 3</b>	<b>INTRODUCTION</b> .....	<b>4</b>
<b>SECTION 4</b>	<b>CONTROL FEATURES</b> .....	<b>5</b>
<b>SECTION 5</b>	<b>INSTALLATION</b> .....	<b>6</b>
<b>SECTION 6</b>	<b>SETUP MODE</b> .....	<b>8</b>
<b>SECTION 7</b>	<b>REVIEW MODE (PRIOR TO CHARGE ONLY)</b> .....	<b>9</b>
<b>SECTION 8</b>	<b>CHARGING MODE</b> .....	<b>10</b>
<b>SECTION 9</b>	<b>FAILURE MODE</b> .....	<b>15</b>
<b>SECTION 10</b>	<b>CHARGER CABINET</b> .....	<b>16</b>
<b>SECTION 11</b>	<b>MONTHLY PREVENTIVE MAINTENANCE</b> .....	<b>16</b>
<b>SECTION 12</b>	<b>TROUBLESHOOTING GUIDE</b> .....	<b>17</b>
<b>SECTION 13</b>	<b>SCHEMATICS</b> .....	<b>18</b>

**SECTION 1****SAFETY INSTRUCTIONS****IMPORTANT SAFETY INSTRUCTIONS**

1. SAVE THESE INSTRUCTIONS. THIS MANUAL CONTAINS IMPORTANT SAFETY AND OPERATING INSTRUCTIONS.
2. WORKING IN THE VICINITY OF A LEAD-ACID BATTERY IS DANGEROUS. BATTERIES GENERATE EXPLOSIVE GASSES DURING NORMAL BATTERY OPERATION. FOR THIS REASON IT IS OF THE UTMOST IMPORTANCE THAT EACH TIME BEFORE USING YOUR CHARGER, YOU READ AND FOLLOW THE INSTRUCTIONS PROVIDED EXACTLY.
3. TO REDUCE RISK OF BATTERY EXPLOSION, FOLLOW THESE INSTRUCTIONS AND THOSE ON THE BATTERY.
4. NEVER SMOKE OR ALLOW AN OPEN SPARK OR FLAME IN THE VICINITY OF THE BATTERY OR ENGINE.
5. USE CHARGER FOR CHARGING A LEAD-ACID BATTERY ONLY. IT IS NOT INTENDED TO SUPPLY POWER TO AN EXTRA LOW-VOLTAGE ELECTRICAL SYSTEM OR TO CHARGE DRY-CELL BATTERIES. CHARGING DRY-CELL BATTERIES MAY CAUSE THEM TO BURST AND CAUSE INJURY TO PERSONS AND DAMAGE TO PROPERTY.
6. NEVER CHARGE A FROZEN BATTERY.
7. DO NOT OPERATE IN A CLOSED-IN AREA OR RESTRICT VENTILATION IN ANY WAY.
8. DANGER: RISK OF ELECTRICAL SHOCK. DO NOT TOUCH UNINSULATED PORTION OF OUTPUT CONNECTOR OR UNINSULATED BATTERY TERMINAL.
9. CAUTION: DISCONNECT SUPPLY BEFORE CHANGING FUSE.

**INSTRUCTIONS IMPORTANTES CONCERNANT LA SECURITE**

1. CONSERVER CES INSTRUCTIONS. CE MANUEL CONTIENT DES INSTRUCTIONS IMPORTANTES CONCERNANT LA SECURITE ET LE FONCTIONNEMENT.
2. IL EST DANGEREUX DE TRAVAILLER A PROXIMITE D'UNE BATTERIE AU PLOMB. LES BATTERIES PRODUISENT DES GAS EXPLOSIFS EN SERVICE NORMAL. AUSSI EST-IL IMPORTANT DE TOUJOURS RELIRE LES INSTRUCTIONS AVANT D'UTILISER LE CHARGEUR ET DE LES SUIVRE A LA LETTRE.
3. POUR REDUIRE LE RISQUE D'EXPLOSION, LIRE CES INSTRUCTIONS ET CELLES QUI FIGURENT SUR LA BATTERIE.
4. NE JAMAIS FUMER PRES DE LA BATTERIE OU DU MOTEUR ET EVITER TOUTE ETINCELLE OU FLAMME NUE A PROXIMITE DE CES DERNIERS.
5. UTILISER LE CHARGEUR POUR CHARGER UNE BATTERIE AU PLOMB UNIQUEMENT. CE CHARGEUR N'EST PAS CONCU POUR ALIMENTER UN RESEAU ELECTRIQUE TRES BASSE TENSION NI POUR CHARGER DES PILES SECHES. LE FAIT D'UTILISER LE CHARGEUR POUR CHARGER DES PILES SECHES POURRAIT ENTRAINER L'ECLATEMENT DES PILES ET CAUSER DES BLESSURES OU DES COMMAGES.
6. NE JAMAIS CHARGER UNE BATTERIE GELEE.
7. NE PAS FAIRE FONCTIONNER LE CHARGEUR DANS UN ESPACE CLOS ET/OU NE PAS GENER LA VENTILATION.
8. DANGER: RISQUE DE CHOCS ELECTRIQUES. NE PAS TOUCHER LES PARTIES NON ISOLEES DU CONNECTEUR DE SORTIE OU LES BORNES NON ISOLEES DE L'ACCUMULATEUR.
9. ATTENTION: COUPER L'ALIMENTATION AVANT DE REMPLACER LES FUSIBLES.



## SECTION 4 CONTROL FEATURES

- 25% recharge in one hour, 80% recharge in approximately three hours and 100% recharge in approximately six hours.

□ No battery modifications are required

□ Easy access for programming all features •

User selectable features:

- Charge rate of 18 or 25A/100Ah
- Delayed start from 30 minutes to four hours, in 15 minute intervals
- Equalize can be selected manually, automatically with day/time setting, or every 5 cycles
- Gassing point options: 2.37VPC, 2.40VPC (default), 2.42VPC, and 2.45VPC
- Automatic refresh charge every 24 hours
- Programmable charge block out time
- Programmable charge termination when battery voltage reaches the gassing point, to prevent excessive gassing

□ Remote Control Interface

□ Auto start with five second delay

- Automatic shutdown for the following conditions:

- 80% or final charge exceeds time limit
- Volts per cell outside safe limits
- Charging current too high or too low
- Maximum battery temperature exceeded (requires optional battery temperature sensor)
- Internal charger temperature exceeded

□ Digital readout displays:

- Time remaining to 80% & full charge
- Charge current/voltage
- Equalize in process
- Charge data 25 cycles (time, AH returned, and voltage)
- Charger setup
- Fault codes

□ LED charge status indicators

- Gas gauge
- Charging
- 80% Charged
- Charge Complete
- Equalize
- Fault Shutdown

□ Cool down time displayed

□ Manual jump start for over-discharged batteries

## SECTION 5 INSTALLATION

### 5.1 PHYSICAL LOCATION:

Charging areas should be clean and dry. The temperature of the charging room should be between 32<sup>o</sup>F (0<sup>o</sup>C) and 104<sup>o</sup>F (40<sup>o</sup>C). Combustible materials, open flames and smoking must not be permitted in or near the charging area. It is very important to keep all four sides, including the fans, free from obstructions; there should be at least 2 feet between the charger front or sides and any other object.

### 5.2 MOUNTING:

The Maverick charger cabinets must be mounted on a surface constructed from non-combustible material, such as stone, brick, concrete or metal. Mounting holes are provided in the frame for securing the charger. Do not use the charger while it is attached to the pallet.

### 5.3 INPUT POWER CONNECTION:

The Maverick chargers are shipped from the factory connected for 480VAC, 3 Phase.

#### **WARNING**

VERIFY THE AC ELECTRICAL SERVICE IS DISCONNECTED AT THE SOURCE  
BEFORE ATTEMPTING TO CONNECT AC POWER TO THE CHARGER.

**CAUTION** To reduce the risk of fire, use only on circuits provided with branch circuit protection indicated in Table 5.3.1 in accordance with the NATIONAL ELECTRIC CODE ANSI/NFPA 70.

Table 5.3.1

MODEL NUMBER	BRANCH CIRCUIT PROTECTION	MODEL NUMBER	BRANCH CIRCUIT PROTECTION
HFC012C1000JMD	15	HFC018C0600JMD	15
HFC012C0865JMD	15	HFC018C0540JMD	15
HFC012C0750JMD	10	HFC018C0475JMD	10
HFC012C0680JMD	10	HFC018C0380JMD	10
HFC012C0600JMD	10	HFC024C0865JMD	20
HFC012C0540JMD	10	HFC024C0750JMD	20
HFC012C0475JMD	10	HFC024C0680JMD	20
HFC012C0380JMD	10	HFC024C0600JMD	20
HFC018C1000JMD	20	HFC024C0540JMD	15
HFC018C0865JMD	20	HFC024C0475JMD	15
HFC018C0750JMD	20	HFC024C0380JMD	10
HFC018C0680JMD	15		

The AC input terminals are identified by a red-on-white AC INPUT label, located on top of the input filter. The AC input cable is to be connected to the proper AC INPUT terminals within the charger cabinet. Refer to table 5.3.2 (next page) for input wire size and torque values.

Table 5.3.2

INPUT FILTER IDENT	WIRE SIZE (STRANDED)	RECOMMENDED TORQUE
16FCD10	12 AWG	6 IN.LBS
25FCD10, 36FCD10	10 AWG	14 IN.LBS

A grounding wire (bare, green or green with yellow stripe) is to be connected from the Grounding Terminal within the charger cabinet to the service system ground. The Grounding Terminal is identified by a green-on-white Ground Terminal Label on top of the input filter. If a system ground is not available, the charger frame must be connected to a driven ground rod, in accordance with National and Local electrical codes. Proper application and tight terminal connections are important in avoiding future problems. The ground terminal is rated for 14 awg to 6 awg wire. The recommended torque setting is shown in Table 5.3.3

Table 5.3.3

Wire Gauge	Recommended Torque Setting
PANDUIT LAMA6-14Q	
6 – 10 AWG	40 in lbs
12 – 14 AWG	15 in lbs
T&B ADR6	
6 AWG	35 in lbs
8 – 14 AWG	20 in lbs

#### 5.4 TEMPERATURE SENSOR INSTALLATION (OPTIONAL)

The battery temperature sensor kit is designed for use with Maverick Chargers. It senses the battery electrolyte temperature and provides the temperature information to the charger control module.



## SECTION 6 SETUP MODE

Most programming features are accessible from the front panel. Setup mode is password protected. All setting parameters are saved in the memory and the power reset does not affect the setting. Press and hold "ENTER" for 5 seconds to enter the Setup Mode. Press and hold "ENTER" 5 seconds again to exit the Setup Mode. The display will automatically return to Charger Ready Mode in one minute if no activities are detected.

Press *Data▲* or *Data▼* to change between menus, increment/decrement the values or toggle yes/no.

Press *Enter* to go to the sub menu, proceed to the next sub -menu or save the setting. Press *◀Equalize* or *Stop▶* to select the digit to be changed

### 6.1 SETUP PROCEDURES

Password is required to enter the setup mode. The factory set password for the first time setup is "123". The user can enter the setup mode using this then change the password. If an incorrect password is entered, the display returns to "000". Use *Data▲*, *Data▼*, *◀Equalize* and *Stop▶* to change the password. Write the new password down and keep it in a safe place.

Table 6.1

Press DATA▲ or DATA▼ to select the menu	Review Menu Description	Press ◀Equalize or Stop▶: to select the digit Press Data▲ or Data▼: to change the values or settings
CLOCK	Clock Setting	DD:HH:MM - MM:DD:YY
80 OFF	Charger Turns Off at Gassing Point Disabled/Enabled	YES NO
FULLCH	Full Charge Period	T ON - DD:HH:MM ...
BLKOUT	Block out Timer Disabled/Enabled	YES NO
BLOCK	Block out Timer Setting	T OFF - DD:HH:MM ...
EQUAL	Auto Equalize	NO EQU 5 CYL TIMED Press ENTER DD HH:MM
DLY ST	Delay Start Setting	SD 0:00 SD 0:15 ... SD 4:00
GASS V	Gassing Point Setting	GPV 2.37 ... GPV 2.45
RATE	Start Rate Setting	HR 25A HR 18A
REFRSH	Refresh Charge Disabled/Enabled	YES NO
TEMP	Temperature Sense/Compensation Disabled/Enabled	YES NO

## 6.2 DEFAULT SETTINGS

Table 6.2

80 OFF	Charger turns off at gassing point - Enabled
FULLCH	Full Charge Period From 1:00 to 5:00 each day
BLKOUT	Block out Timer Disabled
BLOCK	Block out Period 7:00 to 16:00 each day
EQUAL	Auto Equalize at 02:00 Saturday
DLY ST	No Delay Start
GASS V	Gassing point set at 2.37VPC
RATE	Start Rate set at 25A/100AH
REFRSH	Refresh Cycle Enabled
TEMP	Temperature Sensing/Compensation Disabled (Optional Sensor Required)

**SECTION 7 REVIEW MODE (PRIOR TO CHARGE ONLY)**

All programmed setup items and charge data can be reviewed in the Review Mode. Setup Data can only be reviewed prior to charge with battery disconnected. Charge Data can be reviewed any time. While "CHARGER READY" is scrolling, press DATA▲ or DATA▼ to toggle between SETUP (setup information) and CHDATA (charge data). Press ENTER to make a selection.

## 7.1 REVIEW SETUP DATA

Press DATA▲ to select the main menu, press ENTER to review setup, and press DATA▼ to exit the review menu.

Table 7.1

Review Main Menu Press DATA▲ to select	Review Menu Description	Review Sub Menu Press ENTER to view
CLOCK	Clock Setting	DD HH:MM - MM:DD:YY
80 Y 80 N	Charger Turns Off at Gassing Disabled/Enabled	
FULLCH	Full Charge Period	T ON - DD:HH:MM ...
BLKT N BLKT Y	Block out Timer Disabled/Enabled	
BLOCK	Block out Timer Setting	T OFF - DD:HH:MM ...
NO EQU 5 CYL TIMEEQ DD HH:MM	Auto Equalize	
SD 0:00 SD 0:15 ... SD 4:00	Delay Start Setting	
GPV 2.37 ... GPV 2.45	Gassing Point Setting	
HR 25A HR 18A	Start Rate Setting	
REFH Y REFH N	Refresh Charge Disabled/Enabled	
TEMP Y TEMP N	Temp. Sense/Compensation Disabled/Enabled	

## 7.2 REVIEW CHARGE DATA

Press DATA▲ to select the charge cycle, press ENTER to review the setup, and press DATA▼ to exit the review menu.

Table 7.2

Review Main Menu Press DATA▲ to select	Review Menu Description	Review Sub Menu Press ENTER to view
LAST	Charge Data of the Last Cycle Start Month:Date Start Hour:Minute Amp-Hour Returned Finish Month:Date Finish Hour:Minute Finish Voltage	MM:DD ST HH:MM AH0000 MM:DD FT HH:MM FV V.VV
CYL 1	Cycle #1 Start Month:Date Start Hour:Minute Amp-Hour Returned Finish Month:Date Finish Hour:Minute Finish Voltage	MM:DD ST HH:MM XXXXAH MM:DD FT HH:MM FV V.VV
CYL 2	Cycle #2 Start Month:Date Start Hour:Minute Amp-Hour Returned Finish Month:Date Finish Hour:Minute Finish Voltage	MM:DD ST HH:MM XXXXAH MM:DD FT HH:MM FV V.VV
...		
CYL 24	Cycle #24 Start Month:Date Start Hour:Minute Amp-Hour Returned Finish Month:Date Finish Hour:Minute Finish Voltage	MM:DD ST HH:MM XXXXAH MM:DD FT HH:MM FV V.VV

## SECTION 8 CHARGING MODE

### 8.1 DISPLAY AND CONTROL

The front panel provides the following displays and controls to the user during charge:

Six digit Alphanumeric Display: The default display is Charge Time Remaining, the time remaining until 80% charge and until full charge will be displayed. It also displays the fault codes and charge data of the last 25 charge cycles.

“Gas Gauge” Indicator: The gas gauge contains 5 LED indicator bar and two extra LED indicators for “E” and “F”. The five level indicator displays the battery capacity returned. The “E” indicator illuminates until the battery capacity reaches 20% recharged; the “F” indicator illuminates when the battery is fully charged.

Charger Indicator:

- Charging LED (Red)
- 80% Charged (Amber)
- Charge Complete (Blue)

DATA▲ Push Button Switch

The default display is Charge Time remaining. Press DATA▲ to toggle between Charging Voltage/Current and Charge Time Remaining Display

DATA▼ Push Button Switch

Press DATA▼ to enter the Charge Data Review Mode (Refer to Table 8.1)

ENTER Push Button Switch

Press ENTER to lock in the display mode (Charging Voltage/Current or Charge Time Remaining Display)

EQUALIZE Push Button Switch

Press EQUALIZE to set the Equalize Cycle manually

STOP Push Button Switch

Press STOP to shut down the charger manually

REVIEW CHARGE DATA DURING CHARGE

Press DATA▼ then ENTER to review the current cycle data, press DATA▲ to select the next charge cycle, then press ENTER to review the charge data of the selected cycle. Pressing DATA▼ again will exit the review menu and return to the charging display.

Table 8.1

Review Main Menu Press DATA▲ to select	Review Menu Description	Review Sub Menu Press ENTER to view
DATA	Charge Data of the Last Cycle Start Month:Date Start Hour:Minute Amp-Hour Returned	MM:DD ST HH:MM 0000AH
CYL 1	Cycle #1 Start Month:Date Start Hour:Minute Amp-Hour Returned Finish Month:Date Finish Hour:Minute Finish Voltage	MM:DD ST HH:MM XXXXAH MM:DD FT HH:MM FV V.VV
CYL 2	Cycle #2 Start Month:Date Start Hour:Minute Amp-Hour Returned Finish Month:Date Finish Hour:Minute Finish Voltage	MM:DD ST HH:MM XXXXAH MM:DD FT HH:MM FV V.VV
...		
CYL 24	Cycle #24 Start Month:Date Start Hour:Minute Amp-Hour Returned Finish Month:Date Finish Hour:Minute Finish Voltage	MM:DD ST HH:MM XXXXAH MM:DD FT HH:MM FV V.VV

## 8.2 CHARGING THE BATTERY

When a proper battery is connected, the display will initially show START, once the power up sequence has been completed, the display will switch to WAIT. After a few seconds, the display will show the charging current. After the walk-in is complete, the red CHARGING LED will illuminate. The cycle starts with high rate, constant current of 25A/100AH or 18A/100AH, until the gassing voltage is reached. The “E” LED will illuminate at the beginning of charge cycle. The Gas Gauge LEDs will indicate the state of charge.

The *80% point* can be programmed at 2.37, 2.40, 2.42 or 2.45V/Cell in the Setup mode. When the battery voltage reaches the *80% point*, the charger enters the constant voltage mode and the current gradually tapers off. When the programmed *gassing point* is reached:

- If the Gassing Shut-off function is enabled and during the full charge disabled period, the charger shuts off and goes to idle mode in order to prevent the battery from gassing. The charger will display “STOP AT 80” and the 80% CHARGED LED will illuminate. When the full charge enabled period begins, the charger will automatically turn on to complete the full charge cycle. The cool-down time will be displayed and the CHARGE COMPLETE LED will illuminate when the cycle is complete.
- If the Gassing Shut-off function is disabled or during the full charge enabled period, the charger will continue the regular full charge cycle.

In the regular full charge cycle, once the current drops to the finish rate current setting (5A per 100AH), the charge phase will change from constant voltage to constant current. The charge cycle will terminate by DV/DT sensing. The cool-down time “COOL HH:MM” will display, the F and CHARGE COMPLETE LEDs will illuminate at the completion of the full charge cycle.

## 8.3 EQUALIZE

Equalize cycle provides a timed three hour charge extension at the finish rate current after DV/DT termination has been reached.

Auto Equalize: The Auto Equalize is selected by Setup Mode – every 5 charge cycles or at a specific time of day and day of week (once a week). The first digit of the front panel display will display “E” and the EQUALIZE LED will flash to indicate that the Equalize charge is selected. When the charger is actually in the Equalize mode, the “E” will be flashing.

Manual Equalize: The EQUALIZE button, when pushed, will request the Equalize cycle. The first character of the front panel display will display “E” and the EQUALIZE LED will flash to indicate that the Equalize charge is selected. When the charger is actually in the Equalize mode, the “E” will be flashing. Depressing the EQUALIZE button, prior to the Equalize cycle, will cancel the Equalize function.

## 8.4 AUTO EQUALIZE DETAIL

The timed equalize charge, if selected, will occur once a week. The following paragraph outlines this feature in detail.

### AUTO EQUALIZE SELECT

Auto Equalize can be either disabled, activated every 5 charge cycles or activated once a week at a specific time of day and day of week. Refer to Section 6.1 for the Auto Equalize setup

## AUTO EQUALIZE CANCELLATION

- Automatic equalize request cannot be cancelled by pressing the Equalize button. To cancel auto equalize select, press the STOP button to interrupt charge, disconnect then reconnect the battery.
- Manual equalize select can be cancelled by pressing the Equalize button again.

## AUTO EQUALIZE ACTIVATION

When the set time and set day are matched, equalize cycle can be activated under the following conditions:

- When the charge is in progress, the equalize cycle will start immediately after completing the 100% charge cycle.
- When the 100% charge cycle is already completed, the charger will automatically turn on to equalize charge the battery for 3 hours.
- If the 100% charge cycle is not complete, because the battery voltage reached 80% before the full charge enable window was reached (1:00 to 5:00 is default setting of the full charge enable window), the charger will immediately resume to complete the 100% charge, then add three hours of equalize charge.
- If the battery is not connected, the Equalize Cycle will be activated the next time the battery is connected. The charger will remain on throughout the cycle until the Equalize cycle is complete and will not shut off at the gassing point.

## FULL CHARGE TIME WINDOW

- When the battery voltage reaches the 80% point within this window, the charge cycle will continue to fully charge the battery.
- When the battery voltage reaches the 80% point outside this window, the charger will shut off and resume when the ON time is reached.
- When the OFF time is reached, the charge will continue until the charge cycle is complete.
- When the Equalize Time is set before the ON time of the full charge cycle, the charge cycle will resume, the charger will fully charge the battery then continue the 3 hour Equalize cycle.

## AUTO EQUALIZE AND FULL CHARGE ENABLE EXAMPLES

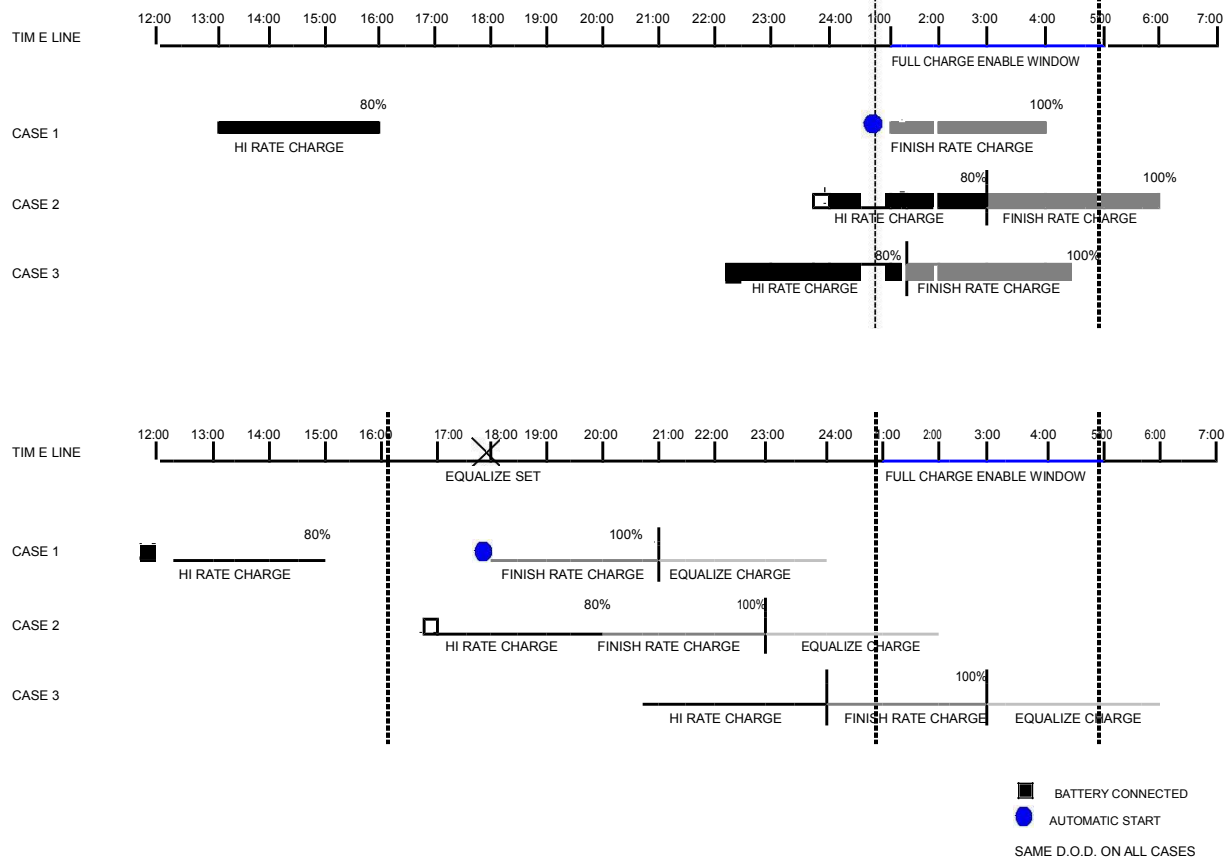

### 8.5 MANUAL TERMINATION

To manually terminate the charge cycle, press the STOP push -button switch located on the front panel. When the charge has been terminated due to manual termination, the red Fault LED will be ON solid until the battery is removed. The display will show "STOP".

### 8.6 REFRESH CHARGE

When a battery remains connected to the charger for 24 hours after the charge has been completed and the Refresh Function is enabled, the control will restart another charge cycle. The charge rate of the battery will be monitored with DV/DT termination occurring typically within 45 minutes. When the charger is in this refresh mode the CHARGING and 80% CHARGED LED's will be ON and the CHARGE COMPLETE LED will be blinking.

### 8.7 TEMPERATURE SENSING (OPTIONAL)

Refer to the user manual of the Temperature Sensor Kit for details

## SECTION 9 FAILURE MODE

### 9.1 PROBLEM SHUTDOWN

The problem shutdown terminations are indicated in Table 9.1. The Fault LED display will remain until the battery is disconnected from the charger. If the battery is disconnected during charge, the display will remain until the battery is connected again.

Table 9.1

Fault Codes	Conditions	LEDs
STOP	STOP button is pressed	Fault LED On
DISC	Battery is unplugged during charge	Fault & Equalize LEDs Flashing
ERR 4	D3 Disconnect Device open (Optional)	Fault LED Flashing
ERR 5	D3 Disconnect Device displaced (Optional)	Fault LED Flashing
ERR 10	Bulk DC Voltage Low During Power-up	Fault LED On
ERR11	Inverter Fault	Fault LED On
ERR12	Bulk DC Voltage Failure during charge	Fault LED On
ERR13	Internal Temperature Sensor Failure	Fault LED On
ERR14	High Internal Temperature	Fault LED On
HIVOLT	Hi Volts (>2.8V/2.85V)	Fault LED On
LOVOLT	Low Volts (<1.7VPC)	Fault LED On
HICURR	Output Current is High (>110%)	Fault LED On
LOCURR	Output Current is Low (<7 Amps)	Fault LED On
DUR HR	Hi Rate Duration (>6 Hours)	Fault LED On
DUR LR	Lo Rate Duration (>6 Hours)	Fault LED On
D3 ACTIVATED	Hot disconnect – D3 safely shut down charger (Optional)	No LED



## 9.2 BATTERY LOW VOLTS OVERRIDE

If the battery voltage measures less than 1.7 VPC, the charger may be started manually, by pressing and holding two push buttons (ENTER and EQUALIZE) for more than 10 seconds. If the battery does not increase above 1.7 V/Cell in 5 minutes the charger will shut off and indicate Low Volts Alarm again, otherwise the normal charge cycle will continue. This "grace period" is intended to give the battery time to recover from its over-discharged condition.

## SECTION 10 CHARGER CABINET

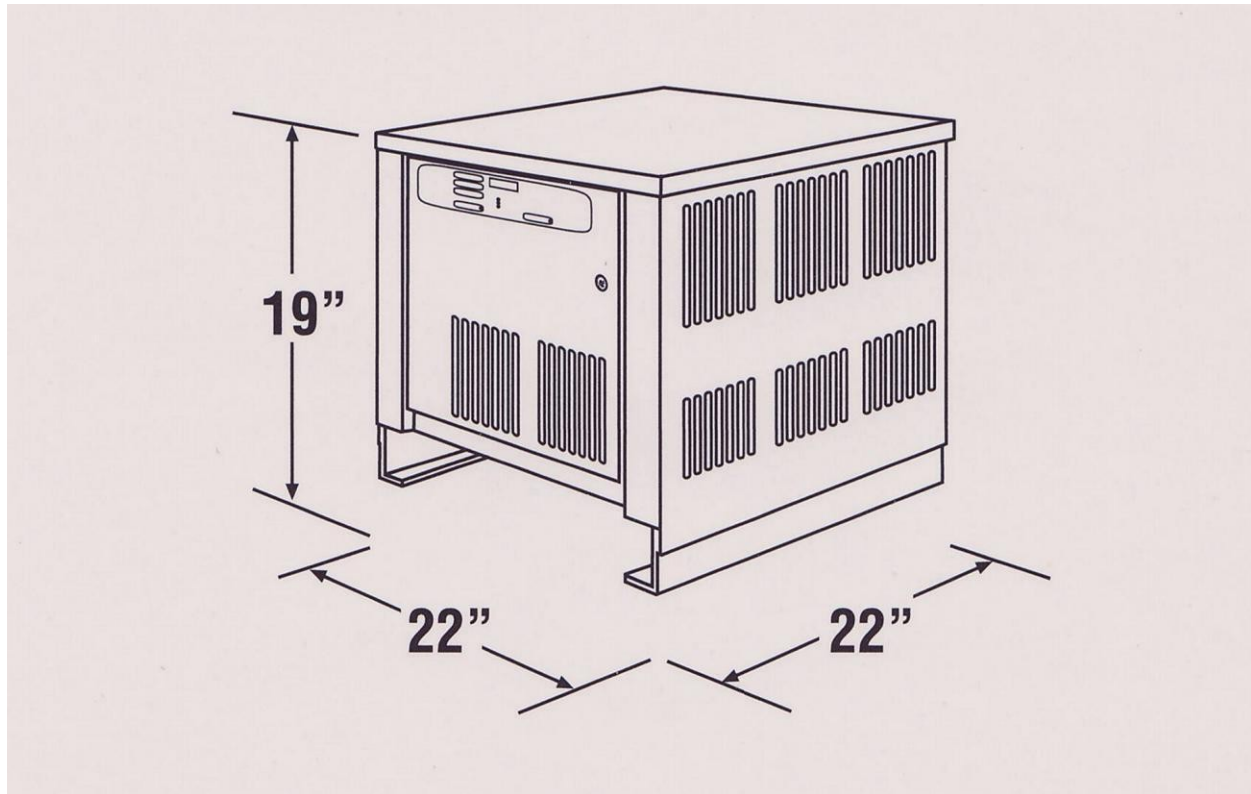

## SECTION 11 MONTHLY PREVENTIVE MAINTENANCE

### 11.1 MONTHLY PREVENTIVE MAINTENANCE

#### **WARNING**

HIGH VOLTAGES EXIST WITHIN THE CHARGER WHICH CAN CAUSE SEVERE INJURY OR DEATH. TO ALLOW INTERNAL COMPONENTS TO DISCHARGE, PLEASE WAIT AT LEAST 2 MINUTES AFTER DISCONNECTING THE AC POWER BEFORE SERVICING. SERVICE SHOULD ONLY BE PERFORMED BY QUALIFIED SERVICE PERSONNEL. IMPROPER SERVICING MAY DAMAGE THE CHARGER.

- If a battery is being charged, terminate the charge by pressing the STOP button.
- Disconnect the battery from the charger.
- Remove AC power from the charger.

- Using compressed air, remove any dust from the two heatsinks (both have fans attached), upper component plate, internal cabinet walls and internal components of the charger.
- Wipe the exterior of the cabinet and clear any obstructions from the fans and ventilation slots.
- Make sure that all bolted or screwed electrical connections are tight.
- Make sure that the insulation on all cables and wires are in good condition. Replace if necessary.
- Replace fan filters if necessary.

## 11.2 CHARGER ADJUSTMENTS

### 11.2.1 Changing the AC Input Line Voltage

Maverick chargers are designed to operate at 480VAC only. The input voltage cannot be changed.

## SECTION 12 TROUBLESHOOTING GUIDE

### ***SYMPTOM 1 POWER IS APPLIED BUT THE DISPLAY IS NOT ON***

- Make sure the input line from the AC power outlet is connected at the AC input filter properly. Verify the AC voltage at the input filter.
- Locate the control transformers. Verify the voltage at the primary of each transformer. If there is no voltage, check the wiring between the control transformers and the contactor.
- Verify the secondary voltage of the small control transformer across terminals 5 and 7. The voltage should be approximately 18-20 Volts RMS. If there is no voltage, the transformer is defective and should be replaced.

### ***SYMPTOM 2 DISPLAY IS ON BUT CHARGER WILL NOT START***

#### **WARNING**

HIGH VOLTAGES EXIST WITHIN THE CHARGER WHICH CAN CAUSE SEVERE INJURY OR DEATH. TO ALLOW INTERNAL COMPONENTS TO DISCHARGE, PLEASE WAIT AT LEAST 2 MINUTES AFTER DISCONNECTING THE AC POWER BEFORE SERVICING. SERVICE SHOULD ONLY BE PERFORMED BY QUALIFIED SERVICE PERSONNEL. IMPROPER SERVICING MAY DAMAGE THE CHARGER.

- If the "**CHARGER READY**" is displayed, check the battery connections and the output fuse for open fuse.
- If "**HIVOLT**" is displayed, verify that the number of cells of the battery to be charged matches the number of cells on the nameplate.
- If "**LOVOLT**" is displayed, verify that the number of cells of the battery to be charged matches the number of cells on the nameplate. If the number of cells matches, the battery might have been over-discharged. Refer to Section 9.2 for Low Volts Override operation.

**SYMPTOM 3 CHARGE TERMINATES EARLY**

- Fault code **“LOVOLT”** - Low volts per cell - the average battery voltage is less than 1.7 V/Cell. Check for bad cells.
- Fault code **“HIVOLT”** - High volts per cell - the average battery voltage is greater than the

high voltage limit. The battery may be fully charged before connecting to the charger. •

Fault code **“DISC”** - Battery is disconnected from charger during charge.

- Fault code **“DUR HR”** or **“DUR FR”** - Charge time exceeded – the battery voltage did not reach the gassing point within the specified time in High Rate or does not shut off within 6 hours from Gassing Point. Check for bad cells or deep discharge condition.
- Fault code **“LOCURR”** - Low charging current – no charging current detected or charging current is too low. Check the DC fuse for open.
- Display **“STOP”** - Charge cycle is terminated by pressing the STOP button.

**Explanation of Fault Codes**

- ERR 4 – D3 disconnect device is open or faulty. Check D3 connections to board.
- ERR 5 – D3 disconnect device displace during charge. D3 device was moved during charge, battery is still connected.
- ERR 10 – Bulk dc voltage is low or not present during power up sequence. Check input voltage.
- ERR 11 – Bypass contactor failure during power up or during charge. Verify coil connectionstocontactor.
- ERR 12 – Bulk dc voltage is low or not present during charge. Check input voltage.
- ERR 13 – One or both of the internal temperature sensors has failed. Please contact factory for assistance.
- ERR 14 – Internal component has overheated. Charger has shutdown to protect components. Please check that both fans operate and fan filters are clean, replace them if necessary.

**SECTION 13 SCHEMATICS**

*See following page*

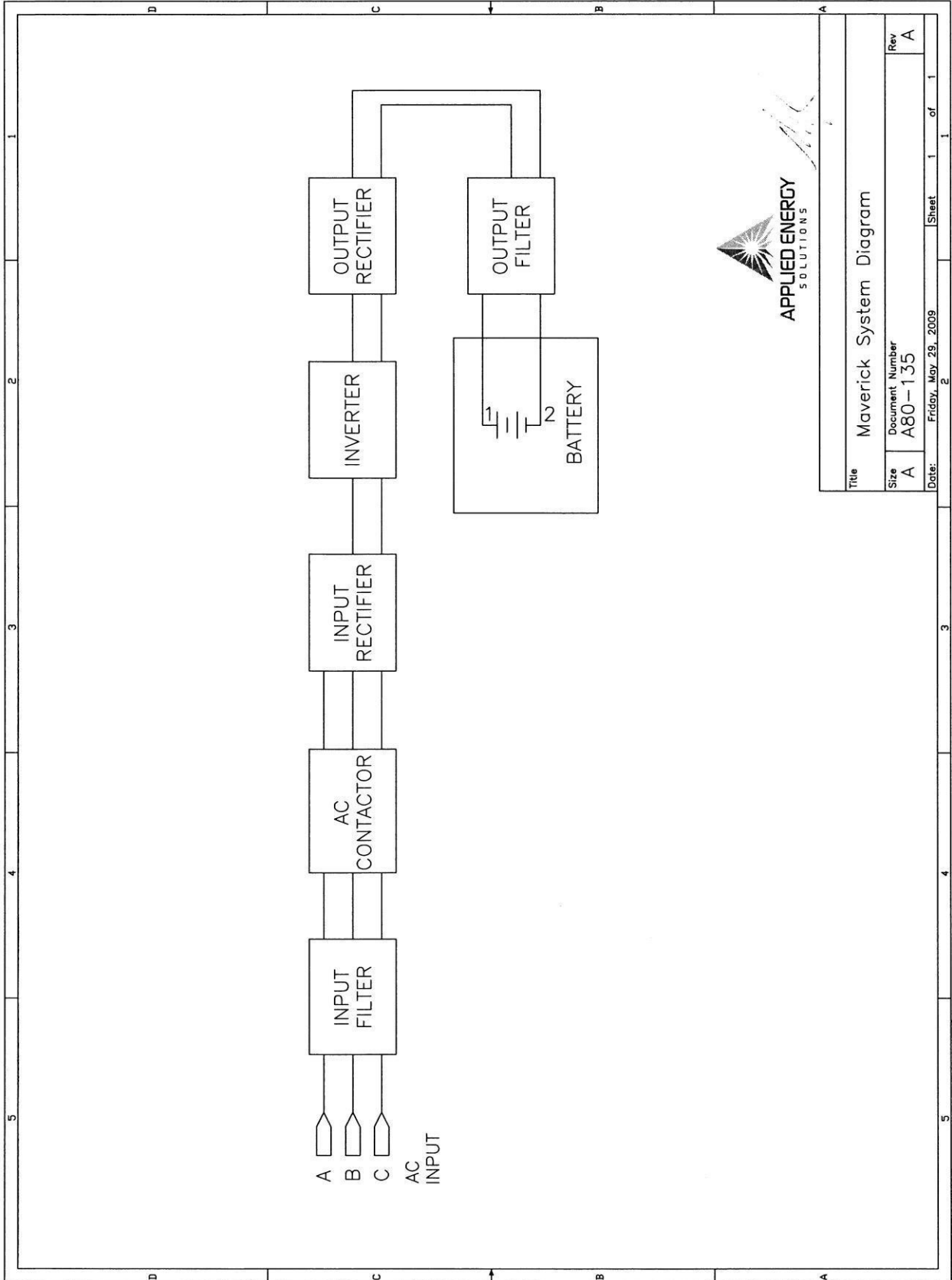

## **CHARGER WARRANTY**

APPLIED ENERGY SOLUTIONS warrants that each new and unused battery charger manufactured and supplied with good workmanship is free from any known mechanical defect, provided that (A) the product is installed and operated in accordance with the accepted industrial standards and in accordance with the printed instructions furnished by APPLIED ENERGY SOLUTIONS, (B) the product is used under normal conditions for which designed, (C) the product is not used in a corrosive, abnormally dusty or high humidity moisture condensing environment, and (D) the product is not subjected to misuse or negligence, and the product receives proper care, protection and maintenance under supervision of competent personnel.

### **Warranty Terms and Conditions**

APPLIED ENERGY SOLUTIONS Maverick Industrial Battery Chargers are warranted for 3 Years<sup>(1)</sup>, which begins on the date of shipment from APPLIED ENERGY SOLUTIONS.

NOTES: <sup>(1)</sup> Warranty covers parts and labor,

AC fuses and DC fuses are not warranted unless they are found to be defective prior to use.

NON-TRANSFERABLE WARRANTY. This warranty is extended by APPLIED ENERGY SOLUTIONS only to the original user (purchaser) of new equipment from APPLIED ENERGY SOLUTIONS or one of its authorized agents. The product purchased under this agreement shall be used exclusively by the buyer. There shall be no third party beneficiary of this warranty.

REPAIR LIMITATIONS. APPLIED ENERGY SOLUTIONS has the right to site inspection and judgment of the claimed defects in any product covered by this warranty. APPLIED ENERGY SOLUTIONS' liability is limited to the repair of any defects found to exist by APPLIED ENERGY SOLUTIONS or, at APPLIED ENERGY SOLUTIONS' option, the replacement of the defective product.

APPLIED ENERGY SOLUTIONS and its authorized agents shall not be liable for direct or indirect damages in excess of such repair or replacement. In no event shall the purchaser be entitled to recover for contingent expenses from, but not limited to, telephone calls, telegrams, travel expenses, lodging, duties and taxes, labor, rental or replacement equipment, loss of business or profit or other commercial losses.

CONTINUED USE OF DEFECTIVE PRODUCTS. The continued use of an APPLIED ENERGY SOLUTIONS Industrial Battery Charger that is known to be defective VOIDS ALL WARRANTIES.

REPAIR OF MODIFIED EQUIPMENT. Except as authorized in writing the warranty specified does not cover any equipment that has been repaired by any party other than APPLIED ENERGY SOLUTIONS or its authorized agents. Except as authorized in writing the warranty specified does not cover any equipment that has been modified, mechanically or electrically, by any party other than APPLIED ENERGY SOLUTIONS.

WARRANTY EXPENSE LIMITATIONS. APPLIED ENERGY SOLUTIONS will limit the warranty expense of all chargers to be paid at a maximum of the original purchase price of the charger.

The provisions of this warranty shall not apply to product in use outside of the continental USA.

Except as stated above, all other warranties and conditions, either expressed or implied, including implied warranties of merchantability and fitness for a particular purpose, are excluded and buyer assumes all risk and liability resulting from the use of the goods. APPLIED ENERGY SOLUTIONS neither assumes or authorizes any persons to assume for APPLIED ENERGY SOLUTIONS any other liability in connection with the sale or use of the goods sold and there are no oral agreements or warranties collateral to or affecting this written warranty. When installing, servicing or operating these products, safe practices should be used by skilled and qualified technical persons.